



Goethe dans son «traité de la couleur» ne soupçonnait pas encore l'existence des cônes et bâtonnets permettant de discerner toutes les nuances du spectre lumineux. A travers une palette colorée, cette collection de suspensions vient à propos nous rappeler cette faculté.

Goethe in his 'treatise on colour' did not yet suspect the existence of cones and rods to discern all shades of the light spectrum. Through a colourful palette, this suspension collection reminds us of this faculty.



Astrid Dieterlen & Bruno Borrione
Designers

Finitions - Finishes



Antiquaire
Antique
Réf. : 400021401033



Vieil antique
Old antique
Réf. : 400021401833



Laiton satin
Brushed brass
Réf. : 400021401183



Laiton poli
Bright brass
Réf. : 400021401603



Nickel satin
Brushed nickel
Réf. : 400021401163



Nickel poli
Bright nickel
Réf. : 400021401363



Aubergine
Aubergine
Réf. : 400021401583



Noir mat
Matt black
Réf. : 400021401733



Blanc mat
Matt white
Réf. : 400021401673



Brut
Unfinished
Réf. : 400021401993

CARACTÉRISTIQUES

Général

Type	Suspension
Matériau	Laiton
Poids net	2,5 kg
Indice de protection	IP 20
Dimensions	323 x 57 mm

Source

Source non incluse recommandée

G9 | 40 W max | 2700 K | 220-240 V | CRI >90 | 475 Lumen

SPECIFICATIONS

General

Type	Pendant
Material	Brass
Net weight	5.5 lb
IP rating	IP 20
Dimensions	12,71 x 2,24 inches

Source

Light source not included recommended

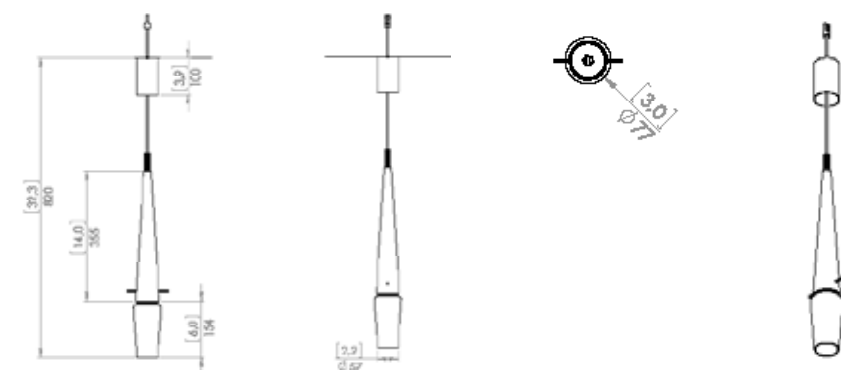

Certaines dimensions peuvent varier légèrement en raison des tolérances de fabrication, y compris l'entrée de câble et les trous de fixation. Ampoule non fournie. Produit disponible pour des marchés spécifiques. Longueurs de câble variées sur demande.

Some dimensions may vary slightly due to manufacturing tolerances, this includes cable entry and fixing holes. Bulb not supplied. This product is available for specific markets. Longer cable lengths are available on request.