



Une écriture de l'évidence. Un tube, une succession de disques et voici un modèle qui rend un humble hommage au pavillon dessiné par Philip Johnson pour l'exposition universelle de 1964. Qu'il était joli notre futur.

Writing the obvious. A tube, a succession of disks and here is a model that pays a humble tribute to the pavilion designed by Philip Johnson for the 1964 World Exhibition. That he was our pretty future.



Astrid Dieterlen & Bruno Borrione
Designers

Finitions - Finishes



Antiquaire
Antique
Réf. : 400021801030



Vieil antiquaire
Old antique
Réf. : 400021801830



Laiton satin
Brushed brass
Réf. : 400021801180



Laiton poli
Bright brass
Réf. : 400021801600



Nickel satin
Brushed nickel
Réf. : 400021801160



Nickel poli
Bright nickel
Réf. : 400021801360



Aubergine
Aubergine
Réf. : 400021801580



Noir mat
Matt black
Réf. : 400021801730



Blanc mat
Matt white
Réf. : 400021801760



Brut
Unfinished
Réf. : 400021801990

CARACTÉRISTIQUES

Général

Type	Lampe à poser
Matériau	Laiton
Poids net	7,5 kg
Indice de protection	IP 20
Dimensions	385 x 451 mm

SPECIFICATIONS

General

Type	Table lamp
Material	Brass
Net weight	16,5 lb
IP rating	IP20
Dimensions	15,16 x 17,76 inches

Source

Source non incluse recommandée

module LED intégré | 30,5 W max | 3000 K | 220-240 V | CRI >80 | 525 Lumen

Source

Light source not included recommended

Light source not included recommended

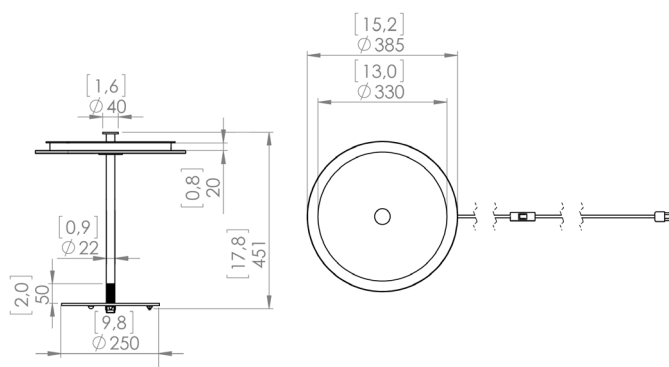

Certaines dimensions peuvent varier légèrement en raison des tolérances de fabrication, y compris l'entrée de câble et les trous de fixation. Ampoule non fournie. Produit disponible pour des marchés spécifiques. Longueurs de câble variées sur demande.

Some dimensions may vary slightly due to manufacturing tolerances, this includes cable entry and fixing holes. Bulb not supplied. This product is available for specific markets. Longer cable lengths are available in request.